

Polarised Actuating Solenoid in Small Design

10

Product group

G BK P 017

- To VDE 0580
- Miniature design
- For push and pull operation
- Bi-stable operation allows two stable, de-energised positions of armature
- Increased holding force using integrated permanent magnets
- Impulse operation for low power consumption and minimal temperature rise
- Short closing time
- High service life
- Coil to insulation class B
- Electrical connection and protection if mounted properly:
 - spade connectors to DIN 46247
protection rating to DIN VDE 0470/EN 60529 - IP 00
 - plug connector to DIN 43650-C with flat seal
protection rating to DIN VDE 0470/EN 60529 - IP 65
- Mounting via bore holes in magnetic body
- Modifications and special designs on request
- Application:
Textile and packaging machines, office machines,
control technology, general locking applications



Fig. 1: Type G BK P 017 K00 A01



Technical data

G BK P 017 K00	A01	A02
Operating mode	S3 5 %	S3 5 %
Rated Voltage (V)	24	24
drop-out current * (A)	0,3 ... 0,45	0,4 ... 0,6
Rated Power P ₂₀ (W)	36,5	36,5
Stroke s (mm)	3	3
Magnetic force (N)	1,0	2,1
Permanent Holding force (N)	3,0	2,0
Work Rating A _N (Ncm)	0,39	0,63
Closing time t ₁ * (ms)	4,4	3,6
Armature weight m _A (kg)	0,004	0,004
Solenoid weight m _M (kg)	0,032	0,032

* Function of counter-load and impulse duration

Rated voltage \approx 24 VDC, on request the coil winding can be adjusted to a rated voltage of \approx 60 VDC maximum.

The magnetic-force values mentioned in the diagram refer to 90 % of the rated voltage, (U_N = \approx 24 VDC, for other voltages the magnetic force may deviate) and in cold condition.

Owing to natural dispersion, the magnetic-force values may deviate by \pm 10 % from the values indicated in the tables.

Attracting and retracting times are a function of counterload and impulse duration. The attracting time values mentioned in the table were taken at rated voltage, R₂₀, with return spring.

Hot condition is based on:

- rated voltage \approx 24 VDC
- operating mode S3 5%
- reference temperature 35° C
- mounting on heat-insulating base

The technical data were taken from sample solenoids and are estimated values. In production, deviations may occur owing to natural dispersion.

Please make sure that the described devices are suitable for your application. Please find further details and definitions in our  Technical Explanation or, respectively, in VDE 0580.

Function

Solenoid type G BK P 017 K00 A.. is a bi-stable design. In extended position, in which the stroke has to be limited externally, the armature is held by a return spring.

By electrical impulse energisation of the coil, the armature moves into its end position. In this retracted position the armature is held by the holding force of a permanent magnet.

Reverse polarity returns the armature. Size of the counter-impulse depends on counter-load and impulse duration.

Note on the technical harmonisation guidelines within the EU



Electromagnetic solenoids of this product range are subject to the low-voltage guideline 73 / 23 EWG.

To guarantee the targets of this regulation, products are manufactured and inspected to the valid edition of DIN VDE 0580. This also equals a declaration of conformity by the manufacturer.

Note on the EMC (electromagnetic compatibility) guideline 89/336 EWG

Electromagnetic solenoids are not affected by this guideline because neither do they cause electromagnetic disturbances nor can they be disturbed through electromagnetic disturbances. Therefore, the adherence to the EMC guideline has to be guaranteed by the user through appropriate circuitry wiring. Examples for protection circuits can be taken from the corresponding technical documents.

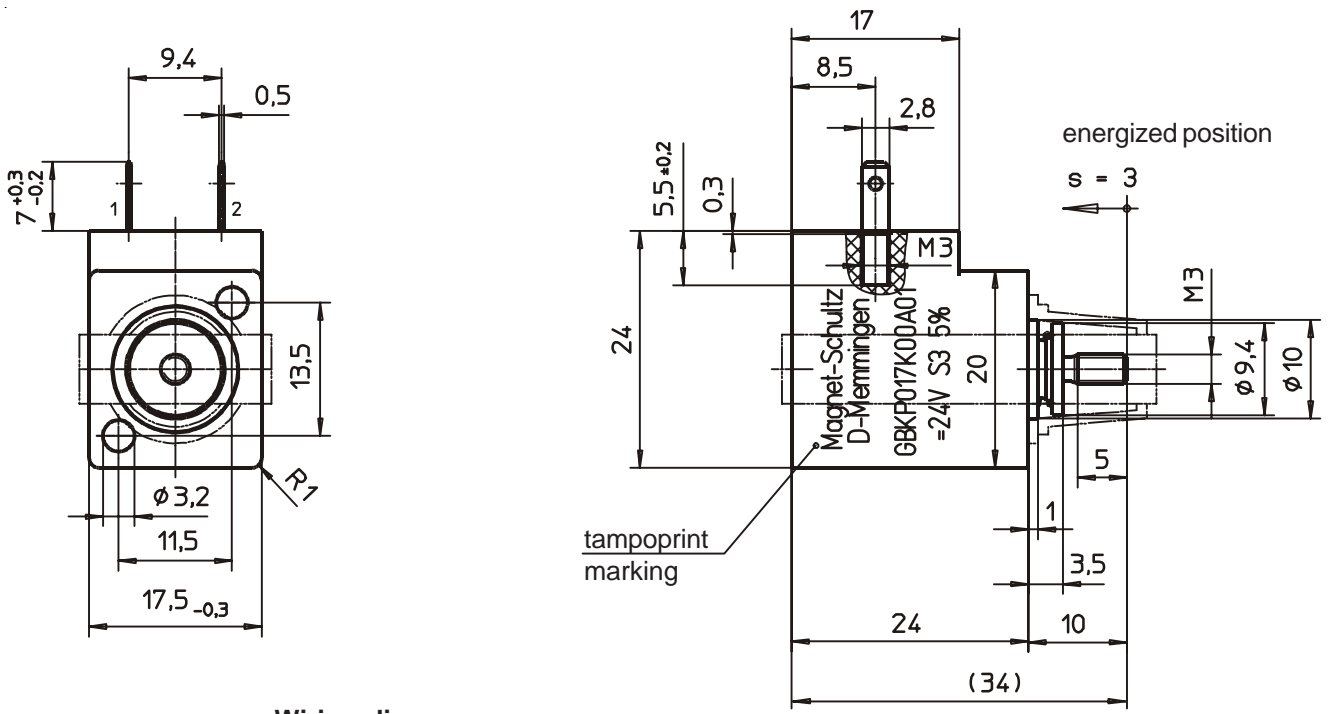

Wiring diagram

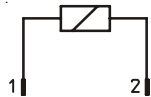

Closing: Pin 1 (-), Pin 2 (+)
 Opening: Pin 1 (+), Pin 2 (-)

The solenoid shown is not a ready-to-use device in the sense of DIN VDE 0580. The general requirements and protective measures to be taken by the user, are included in DIN VDE 0580. The use of the shown device in safety relevant applications needs always the written agreement of MSM.

Fig. 2: Type G BK P 017 K00 A01 / A02

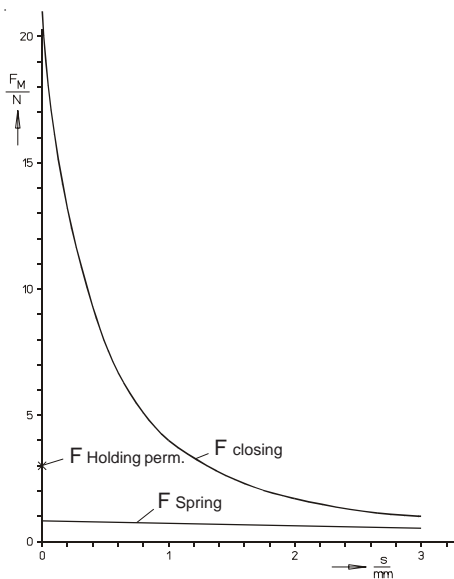

Fig. 3: Magnetic force vs stroke graph
 G BK P 017 K00 A01

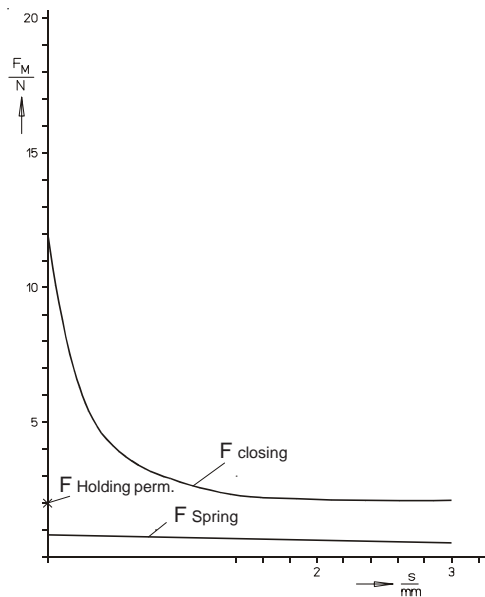
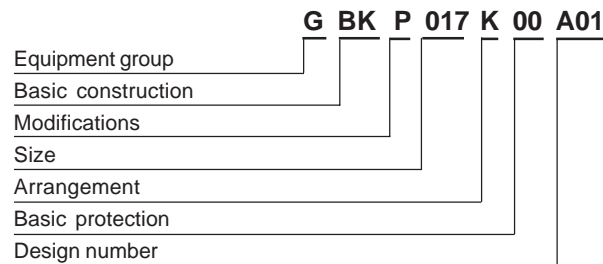



Fig. 4: Magnetic force vs stroke graph
 G BK P 017 K00 A02



Type code



Order Example

Type	G BK P 017 K00 A01
Voltage	 24 V DC
Operating mode	S3 (5 %)

Specials

Please do not hesitate to ask us for application-oriented problem solutions. In order to find rapidly a reliable solution we need complete details about your application conditions. The details should be specified as precisely as possible in accordance with the relevant  - technical explanations.

If necessary, please request the support of our corresponding technical office.