

Proportional Control Solenoids for Hydraulics

4

Product group

G AA X 045

Pamphlet

- To VDE 0580
- Armature space pressure-tight up to 350 bar static pressure
- Increasing magnetic force vs stroke graph
- Push type
- Very small overall height
- Armature guided in pressure-tight armature tube
- Coil insulation rating F
- Electrical connection and protection if mounted properly:
 - Connection with sockets to DIN 46 247
Protection to DIN VDE 0470/EN 60 529 – IP00
 - Connection with plug connector Z KB to DIN 43 650
Screwed cable glands (4 x 90° positions)
Protection to DIN VDE 0470/EN 60 529 – IP 65 (P54)
- Mounting with 4 screws
- Manual override
- Sealing between solenoid and valve through O-ring
- Modifications and special designs on request
- Application examples:
Actuation of hydraulic valves and special valves

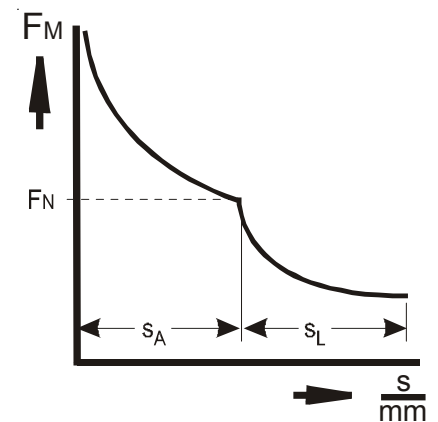

Fig. 1: Magnetic force vs stroke graph



Technical data

G A A X		045
Operating mode		S1
Stroke s	(mm)	Magnetic force F_M (N)
	0	170
	1	68
	2	53
	2,5	52
	3	41
	4	23
	5	13
	5,5	11
Work rating W_N 1)	(Ncm)	13
Rated power \dot{P}	(W)	32,5
Frequency of operating S_h max.	(1/h)	3600
Closing time t_1	(ms)	62
Opening time t_2	(ms)	48
Armature weight m_A	(kg)	0,08
Solenoid weight m_M	(kg)	0,90

Table values (times)

The time values mentioned in the tables refer to rated voltage, maximum stroke, strain through weight, 70% of the rated magnetic force. The may decrease considerably in case of hydraulic strain (slide against spring).

Table values (magnetic force)

The force values mentioned in the tables refer to 90 % of the rated voltage and hot condition.

Owing to natural dispersion, the force values may deviate by 10 % from the values indicated in the tables.

Hot condition is based on:

- mounting on hydraulic slide filled with oil, minimum dimensions 46 x 46 x 66 mm and base plate 46 x 66 x 30 mm
- rated voltage \approx 24 VDC
- operating mode S1
- reference temperature 50° C

In case of deviations from the given application conditions, a winding reduction becomes necessary. For other slide dimensions and reference temperatures, the magnetic force can be adjusted through modification of the exciting winding.

1) Work at working stroke $s_A = 2.5$ mm

Please find further details and definitions in our -Technical Explanation or, in VDE 0580 respectively.

Note on the technical harmonisation guidelines within the EU



Electromagnetic solenoids of this product range are subject to the low-voltage guideline 73 / 23 EWG.

To guarantee the targets of this regulation, products are manufactured and inspected to the valid edition of DIN VDE 0580. This also equals a declaration of conformity by the manufacturer.

Note on the EMC (electromagnetic compatibility) guideline 89/336 EWG

Electromagnetic solenoids are not affected by this guideline because neither do they cause electromagnetic disturbances nor can they be disturbed through electromagnetic disturbances. Therefore, the adherence to the EMC guideline has to be guaranteed by the user through appropriate circuitry wiring. Examples for protection circuits can be taken from the corresponding technical documents.

Dimensions sheet

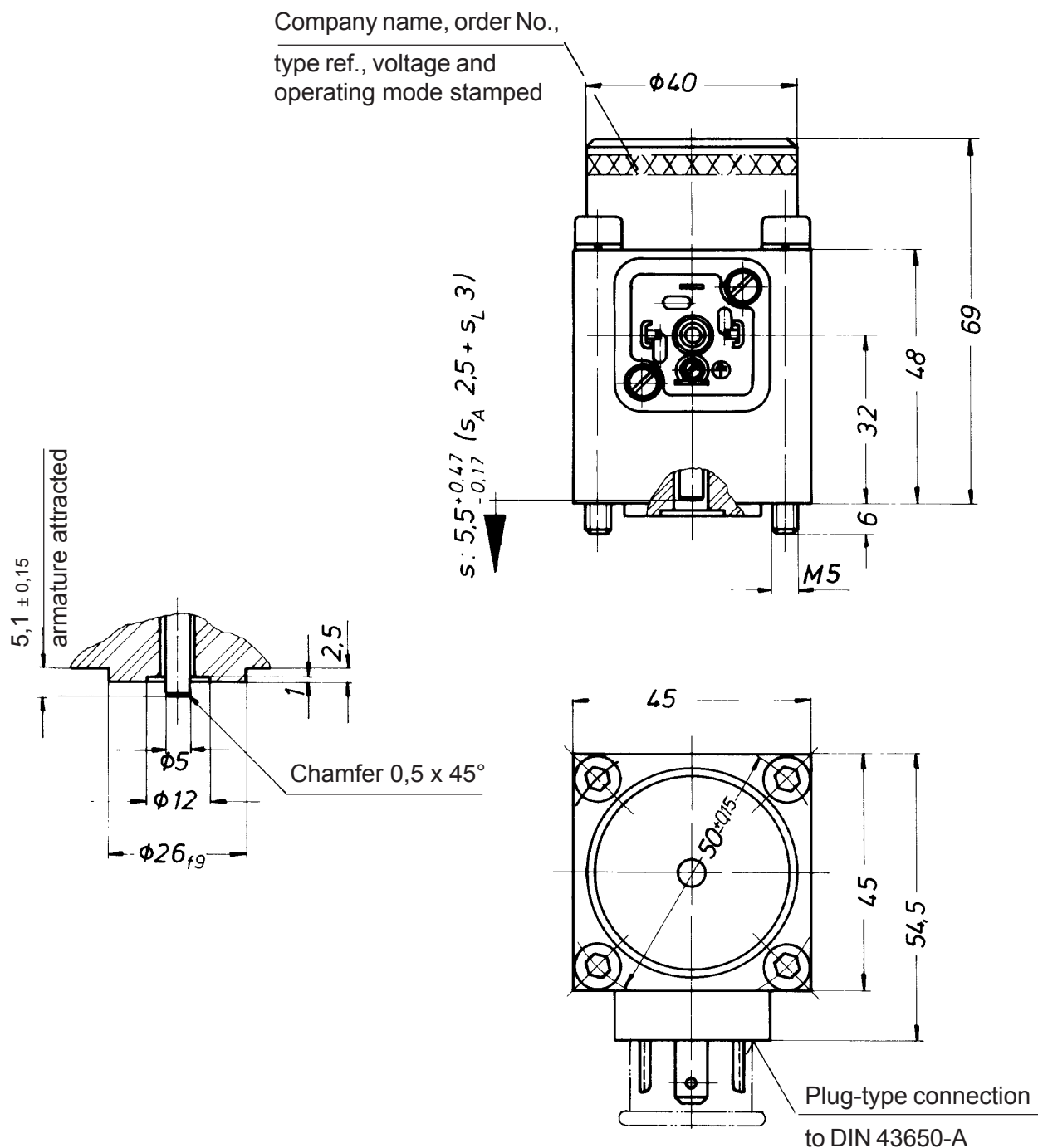
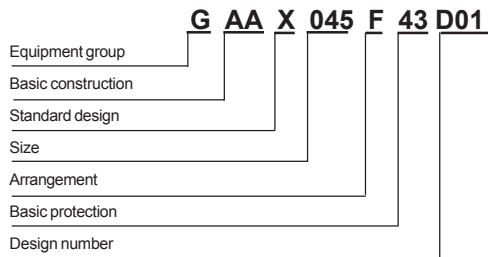

Fig. 2: Type G AA X 045 F43 D01

The solenoid shown is not a ready-to-use device in the sense of DIN VDE 0580. The general requirements and protective measures to be taken by the user are included in DIN VDE 0580.



Type code



Order Example

Type G AA X 45 F43 D01
Voltage == 24 V DC
Operating mode S1

Specials

Special designs and modifications are available on request for which full application conditions should be specified in accordance with our  -Technical Explanations.