

## D.C. or A.C. Valve Solenoid

# 3

Product group

# X BR

- To VDE 0580
- Armature space pressure-tight up to 50 bars static pressure
- Spring-mounted sealing nipples at both ends of the armature
- Coil winding to insulation rating F
- Electrical connection and protection rating if mounted correctly:
- connection by spade connectors to DIN 46247  
protection to DIN VDE 0470/EN60529 IP00

Size 022:

- connection by plug connector Z KC  
cable gland (2 positions x 180°)  
protection to DIN VDE 0470/EN60529 IP65

Size 032:

- connection by plug connector Z KB to DIN 43650  
cable gland (4 positions x 90°)  
protection to DIN VDE 0470/EN60529 IP65

- Centre thread mounting
- Easy exchange of the solenoid body without opening the pneumatic circuit
- Sealing between solenoid and valve through o-ring
- Special designs on request
- Please note that the physically generated noise caused by valve solenoids may be disturbing in quiet rooms, particularly if mounted on a resonant base!
- Application examples:  
Actuation of 2/2 and 3/2 way valves, particularly for pneumatic application and for other gaseous and liquid, neutral media.



Fig. 1: X BR X 022 K54 A01

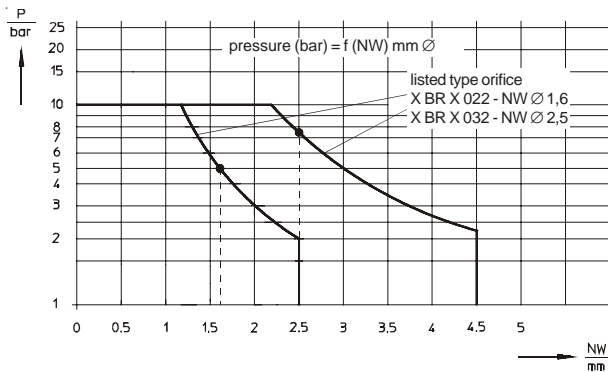

Fig. 2: X BR X 032 K54 A01



**Technical data**

X BR X		022	032	
Operating mode		S1 (100 %)	S1 (100 %)	
Rated Power P <sub>20</sub>	D.C. (W)	4.5	10.6	
	A.C. (VA)	10 / 8	24 / 15	
Stroke s	(mm)	0.5	1	
Reference temperature $\vartheta_{11}$ (°C)		40	60	
Magnetic Force F <sub>M</sub> (without spring)	D.C	stroke 0 mm	15.7	49
		stroke s mm	2.6	8
	A.C	stroke 0 mm	3.4	14.7
		stroke s mm	3.1	7.65
Solenoid weight m <sub>M</sub>	(kg)	0.07	0.23	
Armature weight m <sub>A</sub>	(kg)	0.005	0.02	



**Fig. 3** Switchable pressure as a function of the poppet valve orifice, Listed type orifice = Ø 1,6 mm

These data are valid for the medium compressed air with application as 3/2 way valves de-energize to lock. The exhaust orifice has to be adapted to the valve orifice.

**Please make sure that the described devices are suitable for your application. Please find further details and definitions in our Technical Explanation or, respectively, in VDE 0580.**

We recommend to use compressed air to DIN ISO 8573/1, rating 3. For lubricating the compressed air, elastomer-neutral oils are to be used, otherwise please contact the manufacturer.

**Note on the technical harmonisation guidelines within the EU**

Electromagnetic solenoids of this product range are subject to the low-voltage guideline 73 / 23 EWG.

To guarantee the targets of this regulation, products are manufactured and inspected to the valid edition of DIN VDE 0580. This also equals a declaration of conformity by the manufacturer.

Rated voltage  $\underline{\underline{=}}$  24 V, or 230 V / 50 resp., on request an adaption of the winding to a rated voltage of max.  $\underline{\underline{=}}$  230 V, or 250 V / 50 Hz resp. is possible.

The magnetic force values indicated in the table refer to 90 % of the rated voltage, without spring ( $U_N = \underline{\underline{=}}$  24 V, or 230 V / 50 Hz resp., magnetic force may deviate with other voltages) and hot condition. The magnetic-force values may deviate by approx.  $\pm$  10 % from the table values due to natural dispersion.

The hot condition is based on

- a) mounting on a valve block of brass with dimensions 26 x 16 x 14 mm at size 022 and 50 x 32 x 25 mm at size 032
- b) rated voltage  $\underline{\underline{=}}$  24 V, or 230 V / 50 Hz resp.
- c) operating mode S1
- d) reference temperature 40° C - at size 022 and 60° C - at size 032

Operating times and max. switching frequency are not indicated, because they depend on the particular operating case and on the pressure. The max. switching frequency may be up to 36,000 s/h, depending on the application.

**Note on the EMC (electromagnetic compatibility) guideline 89/336 EWG**

Electromagnetic solenoids are not affected by this guideline because neither do they cause electromagnetic disturbances nor can they be disturbed through electromagnetic disturbances. Therefore, the adherence to the EMC guideline has to be guaranteed by the user through appropriate circuitry wiring. Examples for protection circuits can be taken from the corresponding technical documents.





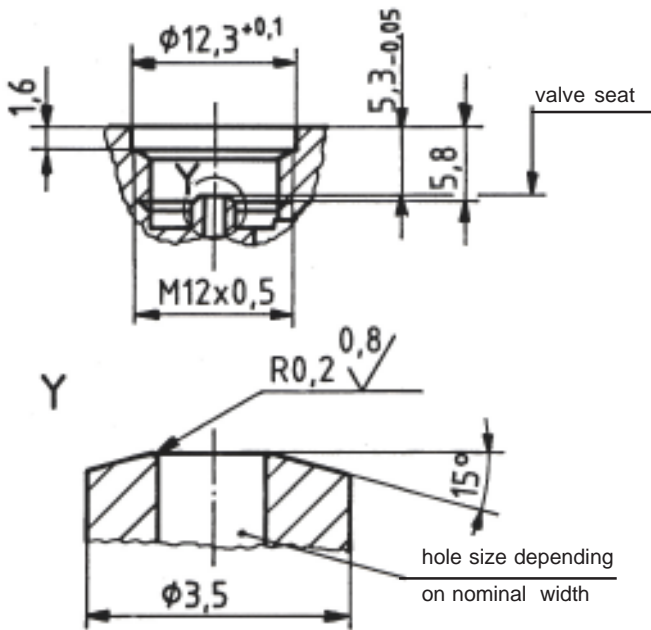

Fig. 6: Valve to X BR X 022

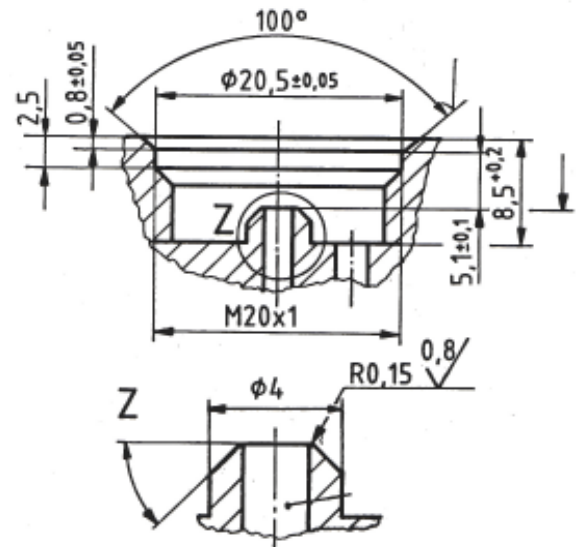

Fig. 7: Valve to X BR X 032

Guiding values for the valve construction corresponding to the indicated listed values (stroke and rated orifice).

The valve construction to be made according to fig. 6 and 7.

The valve seat with largest possible rectangularity to the armature axis of the solenoid and a conical profile with a smooth surface ensure a maximum performance and service life of the solenoid valve.

### Application example

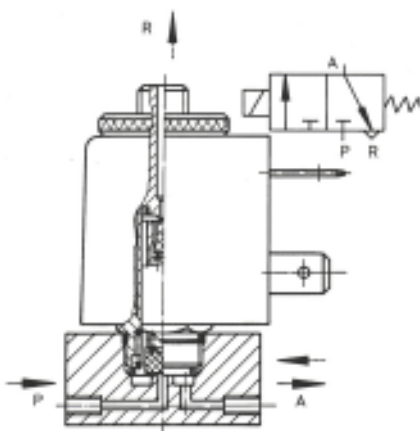

Fig. 8: X BR X 022 K 54 A01 or X BR X 032 K 54 A01 for 3/2-way valve, NC

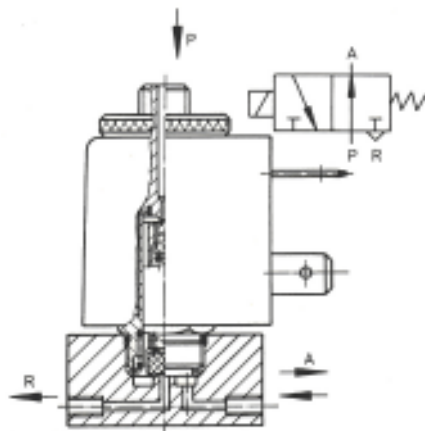

Fig. 9: X BR X 022 K 54 A02 or X BR X 032 K 54 A02 for 3/2-way valve, NO

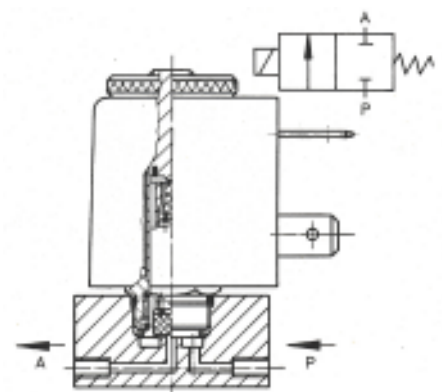
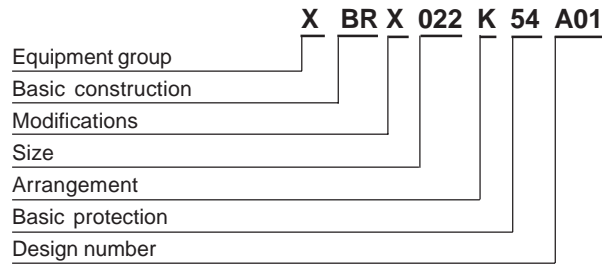



Fig. 10: X BR X 022 K 54 A03 or X BR X 032 K 54 A03 for 2/2-way valve



## Type code



## Order Example

DC:	Type	X BR X 022 K54 A01
	Voltage	 24 V
	Relative duty rating	S1
AC:	Type	X BR X 022 K54 A01
	Voltage	230 V / 50 Hz
	Relative duty rating	S1

## Specials

Special designs and modifications are available on request for which full application conditions should be specified in accordance with our  Technical Explanations.