

D.C. or A.C. Valve Solenoid

3

Product group

X BR 017

Pamphlet

- To VDE 0580
- Armature space pressure-tight up to 30 bars static pressure
- Spring-mounted sealing nipples at both ends of the armature
- Coil winding to insulation rating F
- Electrical connection and protection rating if mounted correctly:
 - flat connector: see fig. 4 for dimensions
 - plug connector: make MPM - order ref.:
 - a) MPM 192 - 0.7 N (colour: black)
 - b) MPM 192 - 076 (colour: grey)protection rating of valve solenoid, to DIN VDE 0470/EN 60529 - IP 54
- Mounting via flange with 2 countersunk screws M 2.5 - centre thread on request
- Easy exchange of the solenoid body without opening the pneumatic circuit
- Sealing between solenoid and valve through o-ring
- Modifications and special designs on request
- Please note that the physically generated noise caused by valve solenoids may be disturbing in quiet rooms, particularly if mounted on a resonant base!
- Application examples:
Actuation of 2/2 and 3/2 way valves, particularly for pneumatic application and for other gaseous and liquid, neutral media.



Fig. 1: X BR X 017 K54 A01



Technical data

X BR X 017			
Operating mode		S1	
Power consumption P_{20}	DC	(W)	2.0
	AC	(VA)	3.7 / 2.5
Stroke s		(mm)	0.4
Ambient temperature ϑ		(°C)	50
Rated magnetic force F_M (N)	DC	Stroke s mm	14
		Stroke 0 mm	1.7
without spring	AC	Stroke s mm	5
		Stroke 0 mm	1.75
Solenoid weight m_M		(kg)	0.043
Armature weight m_A		(kg)	0.005

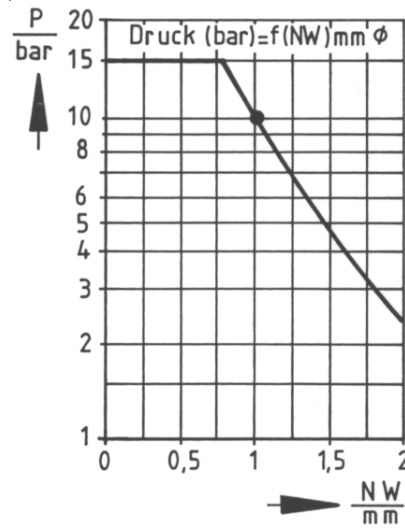

Fig. 2: Fo 0804.1071
Pick-up pressure as function of the valve seat orifice for type X BR X 017

Preferential voltage = 24 V or 24 V / 50 Hz

Higher voltages up to = 160 V or 240 V / 50 - 60 Hz on request.

The magnetic force values indicated in the table refer to 90 % of the rated voltage, without spring ($U_N = = 24$ V, or 24 V / 60 Hz resp., magnetic force may deviate with other voltages) and hot condition. The magnetic-force values may deviate by approx. ± 10 % from the table values due to natural dispersion.

We recommend to use compressed air to DIN ISO 8573/1, rating 3. For lubricating the compressed air, elastomer-neutral oils are to be used, otherwise please contact the manufacturer.

Please find further details and definitions in our -Technical Explanation or, in VDE 0580 respectively.

Note on the technical harmonisation guidelines within the EU

Electromagnetic solenoids of this product range are subject to the low-voltage guideline 73 / 23 EWG.

To guarantee the targets of this regulation, products are manufactured and inspected to the valid edition of DIN VDE 0580. This also equals a declaration of conformity by the manufacturer.

These data are valid for the medium compressed air with application as 3/2 way valves de-energize to lock. The exhaust orifice has to be adapted to the valve orifice.

- The hot condition is based on
- mounting on a heat insulating base
 - rated voltage = 24 V, or 24 V / 50 Hz resp.
 - operating mode S1
 - reference temperature 50° C.

Operating times and max. switching frequency are not indicated, because they depend on the particular operating case and on the pressure. The max. switching frequency may be up to 36,000 s/h, depending on the application.

Note on the EMC (electromagnetic compatibility) guideline 89/336 EWG

Electromagnetic solenoids are not affected by this guideline because neither do they cause electromagnetic disturbances nor can they be disturbed through electromagnetic disturbances. Therefore, the adherence to the EMC guideline has to be guaranteed by the user through appropriate circuitry wiring. Examples for protection circuits can be taken from the corresponding technical documents.

Dimensions sheet

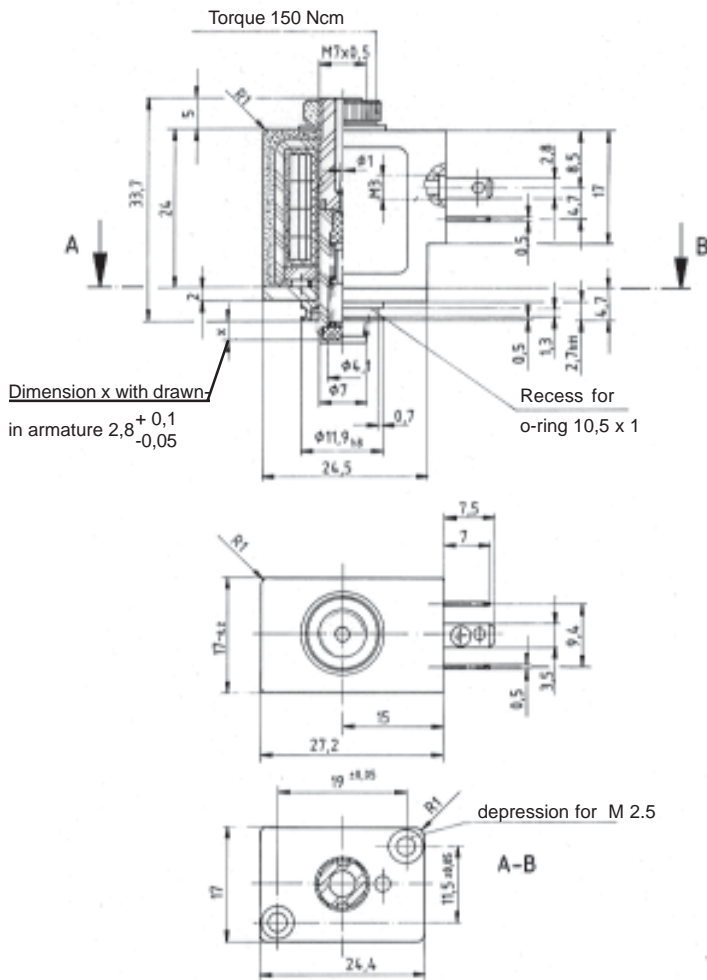

The solenoid shown is not a ready-to-use device in the sense of DIN VDE 0580. The general requirements and protective measures to be taken by the user, are included in DIN VDE 0580.

Fig. 3: Design with flange
 X BR X 017 K54 A01
 X BR X 017 K54 A02
 X BR X 017 K54 A03
 (without exhaust port 2.5 ± 0.1)

Example of application and function

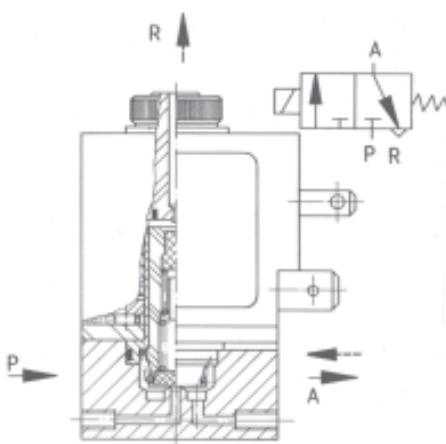

Fig. 4: X BR X 017 K 54 A01
 for 3/2-way valve, NC

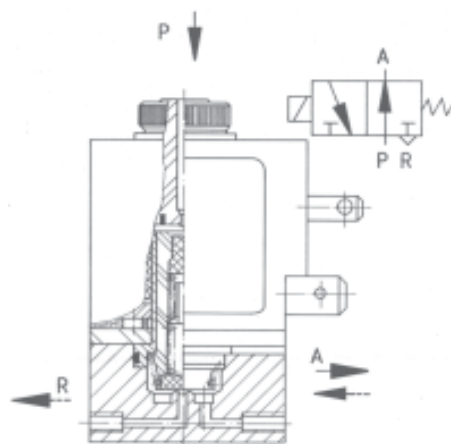

Fig. 5: X BR X 017 K 54 A02
 for 3/2-way valve, NO

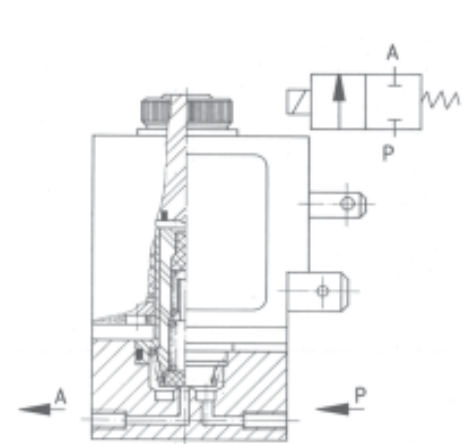
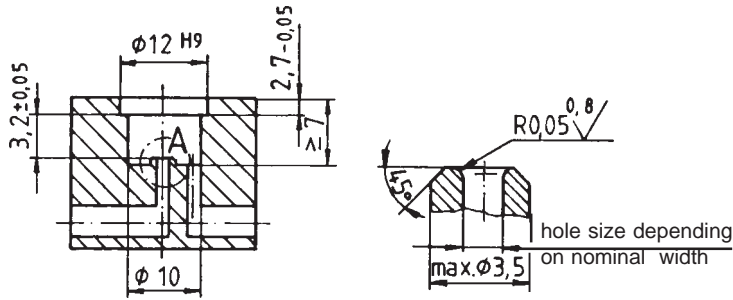

Fig. 6: X BR X 017 K 54 A03
 for 2/2-way valve



Detail A

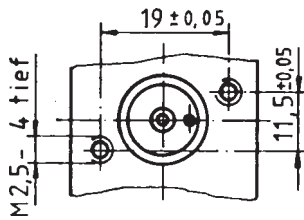

Fig. 7: Fo 0804.1093

Guiding values for the valve construction corresponding to the indicated listed values (stroke and rated orifice).

The valve construction should be made according to fig. 3.

The valve seat with largest possible rectangularity to the armature axis of the solenoid and a conical profile with a smooth surface ensure a maximum performance and life of the solenoid valve.

Type code

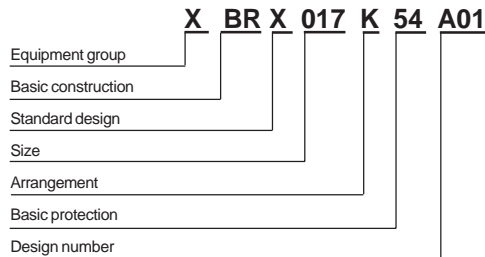

Order Example

DC:	Type	X BR X 017 K54 A01
	Voltage	≡ 24 V
	Relative duty rating	S1
AC:	Type	X BR X 017 K54 A01
	Voltage	≡ 24 V
	Relative duty rating	S1

Specials

Special designs are available on request for which full application conditions should be specified in accordance with our Technical Explanations.