

DC - AC Solenoids

in high-duty and low-watt-design

3

Product group

X BK

- Designed to VDE 0580
- Armature space pressure-tight up to 30 bars static pressure
Rated pressure 10 bar
- Spring-mounted sealing nipples at both ends of the armature,
armature guided in plastic tube, suitable for dry operation
- Armature guided in metal tube type XBKR on request
- Encapsulated design
- Actuation of 2/2 and 3/2 directional seat valves
- Coil insulation rating class F
- Electrical connection and protection rating if mounted properly:
 - Spade connectors to DIN 46247
protection rating to DIN VDE 0470/EN 60529 - IP 00with size 022:
 - Connection with plug connector Z KC
Screwed cable glands (2 positions x 180°)
protection to DIN VDE 0470/EN 60529 - IP 65 (P54)with size 032:
 - Connection with plug connector Z KB
to DIN 43650
protection to DIN VDE 0470/EN 60529 - IP 65 (P54)
- Mounting with 4 screws
- Sealing between solenoid and valve through O-ring
- Modifications and special- or low-watt designs resp. on request
- Please note that the physically generated noise caused by valve solenoids may be disturbing in quiet rooms, particularly if mounted on a resonant base!
- Application examples:
Actuation of 2/2 and 3/2 directional seat valves, particularly for pneumatics, other gaseous media and neutral fluids.



Fig. 1: X BK K 022 K54 A01



Fig. 2: X BK K 032 K54 A01



Technical data

X BK K ... K 54 A01 bis A03 High-duty design			022		032
X BK K ... K 54 A04 bis A06 Low-watt design				022	
Operating mode			S1	S1	S1
Rated power P_{20}	DC	(W)	5.5	2	7.5
	AC	(VA)	10/7	5.7/3.6	16/10
stroke s		(mm)	0.6	0.5	0.8
Reference temperature		(°C)	50	50	50
Magnetic force F_M (N) without spring	DC	stroke 0 mm	30	20	53
		stroke s mm	4.5	2.5	7.5
	AC	stroke 0 mm	10	6.1	20
		stroke s mm	4	3	6.8
Solenoid weight m_M		(kg)	0.085	0.085	0.17
Armature weight m_A		(kg)	0.008	0.008	0.017

Size 032 in low-watt design on request.

Rated voltage $\overline{=}$ 24 VDC or 220 V / 50 Hz resp., on request the coil winding can be adjusted to a rated voltage of max.

$\overline{=}$ 250 V (A01 to A03) 250 V/50 and 60 Hz (A01 to A03)

$\overline{=}$ 110 V (A04 to A06) 250 V/50 and 60 Hz (A04 to A06) maximum.

The magnetic-force values indicated in the tables refer to 90 % of the rated voltage, without spring (UN = $\overline{=}$ 24 VDC, for other voltages the magnetic force may deviate) and in hot condition.

Owing to natural dispersion, the magnetic-force values may deviate by 10 % from the values indicated in the tables.

Hot condition is based on:

- a) mounting on heat-insulating base
- b) rated voltage: $\overline{=}$ 24 V, AC 230 V / 50 Hz
- c) operating mode S1 (100 %)
- d) reference temperature 50° C

The times of operation and the max. operation frequency are not given as these depend on the operation case and on the pressure. The max. operation frequency can be up to 36.000 operations per hour.

These data refer to the medium compressed air, and application as 3/2-port directional control valve, de-energized to lock. Technical data for other applications on request. The exhaust orifice has to be adapted to the valve orifice.

We recommend to use compressed air to DIN ISO 8573/1, class 3. For lubricating the compressed air, elastomer-neutral oils have to be used, otherwise the manufacturer should be contacted.

Please make sure that the described devices are suitable for your application. Please find further details and definitions in our Technical Explanation or, respectively, in VDE 0580.

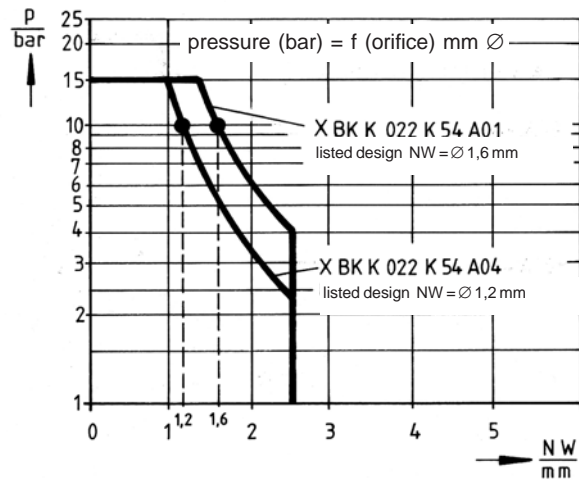

Fig. 3: Pick-up pressure as function of the valve seat orifice for Type X BK K 022

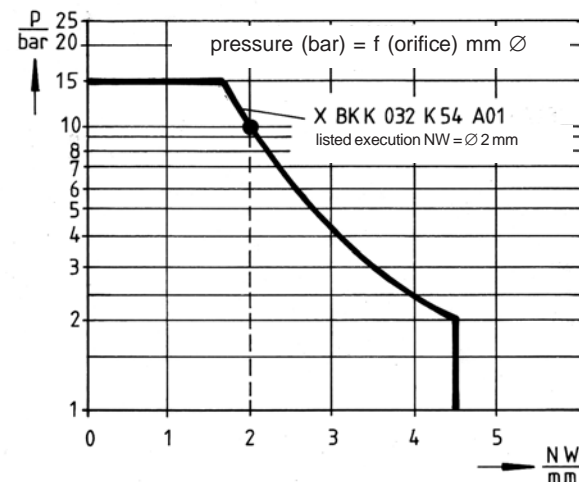

Fig. 4: Pick-up pressure as function of the valve seat orifice for Type X BK K 032

Note on the technical harmonisation guidelines within the EU



Electromagnetic solenoids of this product range are subject to the low-voltage guideline 73 / 23 EWG.

To guarantee the targets of this regulation, products are manufactured and inspected to the valid edition of DIN VDE 0580. This also equals a declaration of conformity by the manufacturer.

Note on the EMC (electromagnetic compatibility) guideline 89/336 EWG

Electromagnetic solenoids are not affected by this guideline because neither do they cause electromagnetic disturbances, nor can they be disturbed through electromagnetic disturbances. Therefore, the adherence to the EMC guideline has to be guaranteed by the user through appropriate circuitry wiring. Examples for protection circuits can be taken from the corresponding technical documents.

dimensions

plug connector ZKC on request
(2 x 180°) see pamphlet ZKB ZKC

tightening moment of the
mounting screw max. 0,6 Nm

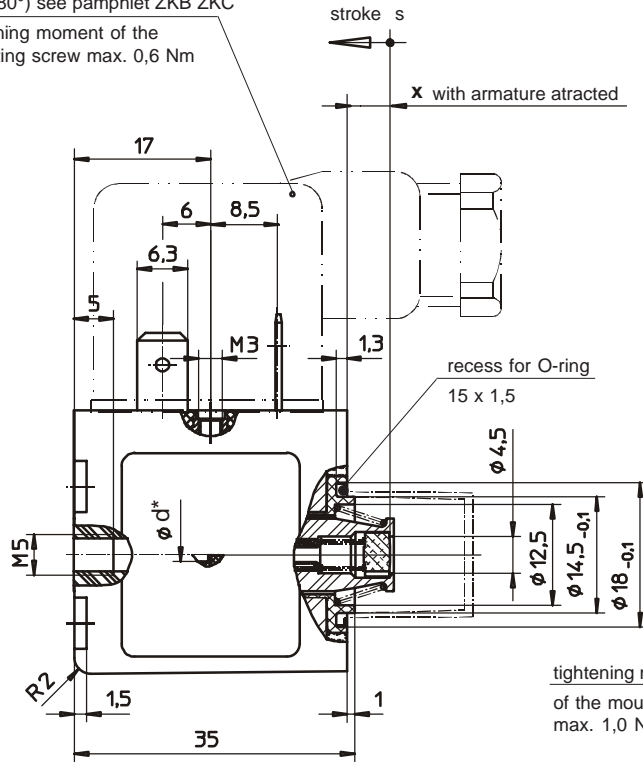

X BK K 022 K54	A01	A02	A03	A04	A05	A06
stroke s	0.6		0.5			
∅ d	1.6	1.6	---	1.2	1.2	---
x with armature closed	4.8 + 0.05 - 0.15		4.8 + 0.05 - 0.15			

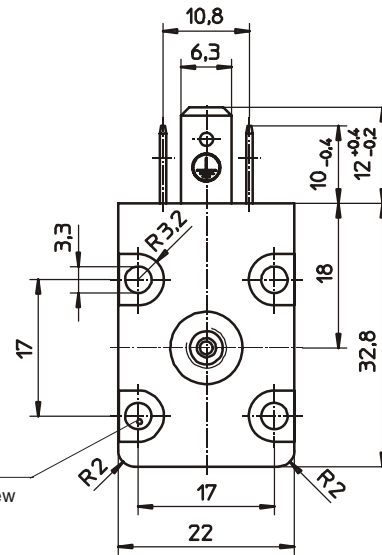

tightening moment
of the mounting screw
max. 1,0 Nm

Fig. 5: Type X BK K 032 K54 A01 to A06
* types A03 and A06 without thread M5 and ∅ d (see fig. 10)

Plug connector Z KB on
request (4 x 90°)
see pamphlet ZKB ZKC
tightening moment of
the mounting screw
max. 0,6 Nm

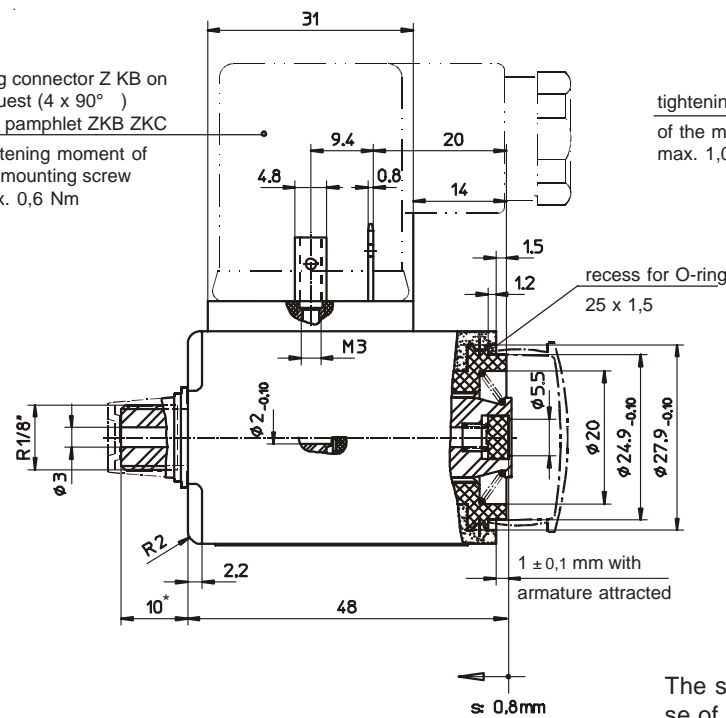

tightening moment
of the mounting screw
max. 1,0 Nm

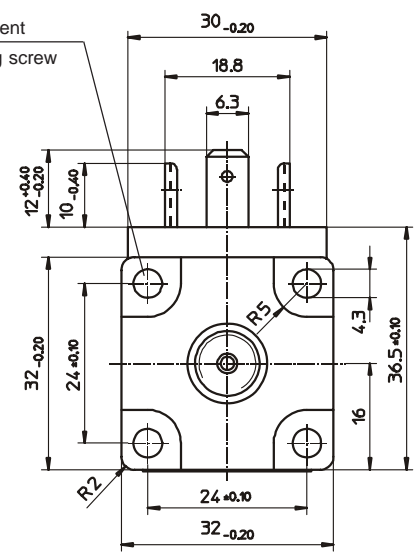

Fig. 6: Type X BK K 032 K54 A01 to A03
* type A03 without thread R 1/8" (see fig. 10)

The solenoids shown are not ready-to-use devices in the sense of DIN VDE 0580. The general requirements and protective measures to be taken by the user, are included in DIN VDE 0580. The use of the shown devices in safety relevant applications need always the written agreement of MSM.

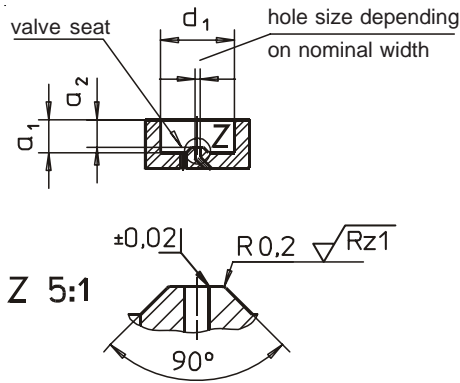

Fig. 7: valve construction Typ X BK K

X BK K	Sizes		
	022	022	032
	A01 bis A03	A04 bis A06	A01 bis A03
dimensions in mm			
∅ d1	14,6	14,6	25
admissible deviations	± 0,05	± 0,05	± 0,05
a1	6,5	6,5	3
admissible deviations	- 0,1	- 0,1	---
a2	5,4	5,3	1,8
admissible deviations	-0,1	-0,1	-0,1

Guiding values for the valve construction corresponding to the indicated listed values (stroke and rated orifice). The valve construction should be made according to fig. 5. The valve seat with the largest possible rectangularity to the armature axis of the solenoid and a conical profile with a smooth surface ensure a maximum performance and life of the solenoid valve.

Example of application and function

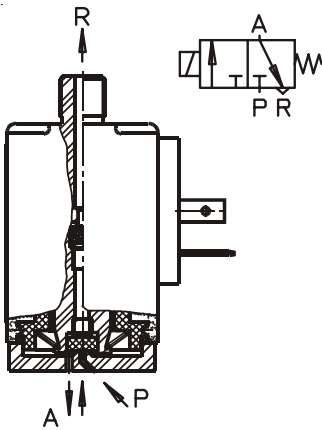

Fig. 8: Types X BK K 022 K54 A01
X BK K 022 K54 A04
X BK K 032 K54 A01
for 3/2-way-valves, normally closed

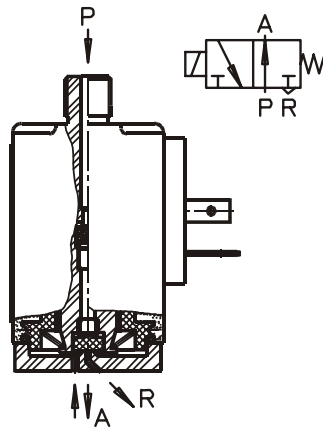

Fig. 9: Types X BK K 022 K54 A02
X BK K 022 K54 A05
X BK K 032 K54 A02
for 3/2-way-valves, normally open

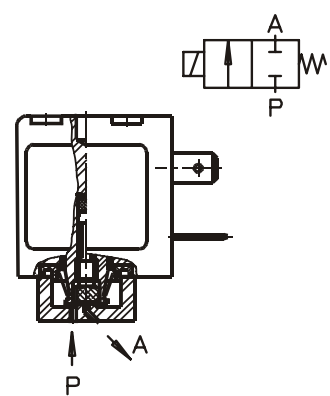
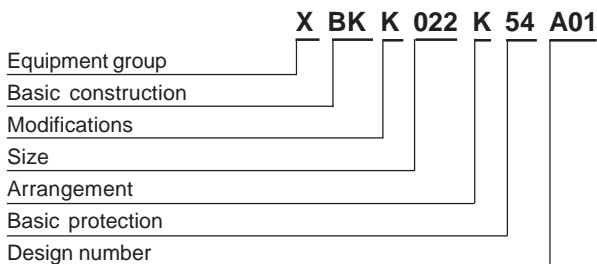

Fig. 10: Types X BK K 022 K54 A03
X BK K 022 K54 A06
X BK K 032 K54 A03
for 2/2-way-valves

Type code



Order Example

DC Type	X BK K 022 K54 A01
Voltage	≡ 24 V DC
Operating mode	S1 (100%)
AC Type	X BK K 022 K54 A01
Voltage	220 V 50 Hz
Operating mode	S1 (100%)

Specials

Special designs and modifications are available on request for which full application conditions should be specified in accordance with our Technical Explanations.