

Inductive Transducer in Round Metal Housing

11

Product group

A WX X

Application

The inductive transducer is used for measuring travel. It can either be flanged to a solenoid or to any other object to be measured. The core, which can be moved within the coils, has to be connected to the object to be measured via the threaded pin. Special features of MSM transducers are high resolution, good linearity and long service life.

In connection with a control unit and a proportional solenoid you get a complete travel-control system. For applications under pressure, sealing between pressure-tight tube and the solenoid or valve through O-ring.

Function

Function of the inductive transducer is based on the principle function of a differential transformer. The device has to be supplied with alternating voltage. The difference in the voltages induced in the secondary coils is a measure for the position of the core, taking into account the phase position, is a measure for the position of the core.

Design features

- Optimised temperature drift
- Suitable for dry and pressure-tight applications
- Pressure-tight tube, designed for 350 bar static pressure
- Mounting by fit on tube
- Electrical connection and protection rating if mounted properly:
 - Connection with lead with contacts and connector housing (shell)
 - Protection to DIN VDE 0470 / EN 60529 – IP 54
- Threaded pin for fastening the core to the object to be measured



Fig. 1: A WX X 010 A01



Technical data

		A WX X 007 A01	A WX X 010 A01
Measuring path	(mm)	± 4.5 / ± 7.5 mm	± 10
Supply voltage U_B (recommended)	(~ V_{rms})	3.54	3
Supply frequency	(kHz)	5	2.5
Sensitivity	$\left[\frac{mV}{V \cdot mm} \right]$	60 ± 5 %	27 ± 5 %
Output voltage	(~ V_{rms})	0 ... 1.59	0 ... 0.27
Input impedance	(Ω)	≥ 380	≤ 160
Output impedance	(Ω)	≤ 1500	≤ 400
Linearity tolerance	(%)		± 1
up to $s = 4.5$ mm	(%)	± 0.6	
up to $s = 7.5$ mm	(%)	± 3	
Reference temper. range	(°C)	- 20 ... + 90°	- 20 ... + 90°
Temperature drift	(% / K)	0.015	0.007

Sensitivity for A WX X 007 A01

Sensitivity is the change in the output signal with reference to the change in the measuring path and the output voltage U_B .

(indicated in $\left[\frac{mV}{V \cdot mm} \right]$).

$$\text{Sensitivity} = \frac{\Delta U}{U_B \times \Delta s}$$

Linearity error

The linearity error indicates the deviation of the output signal from the ideal graph in per cent.

$$\text{deviation}_{Lin} = \frac{(U_{actual} - U_{nominal})}{U_{voltage\ stroke}} \times 100 \%$$

Temperature drift

Temperature drift indicates in per cent the deviation of the output signal per degree of temperature change (shown in % / °K).

$$\text{deviation}_{Temp.} = \frac{(U_{Temp} - U_{20^\circ C})}{U_{voltage\ stroke} \times \Delta T} \times 100 \%$$

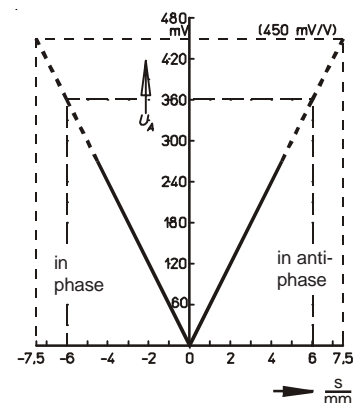

Fig. 2: Voltage vs travel diagram for transducer A WX X 007A01

Dimensions sheet

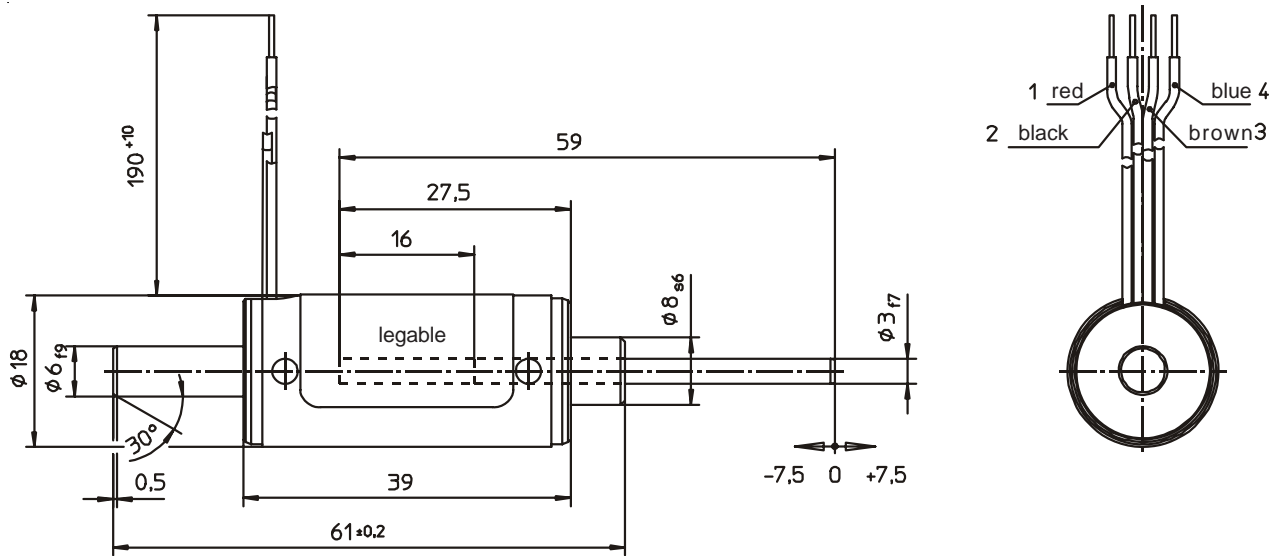

Fig. 3: Type A WX X 007 A01

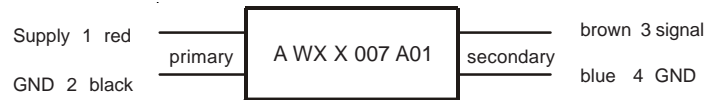

Fig. 4: Connection diagram A WX X 007 A01

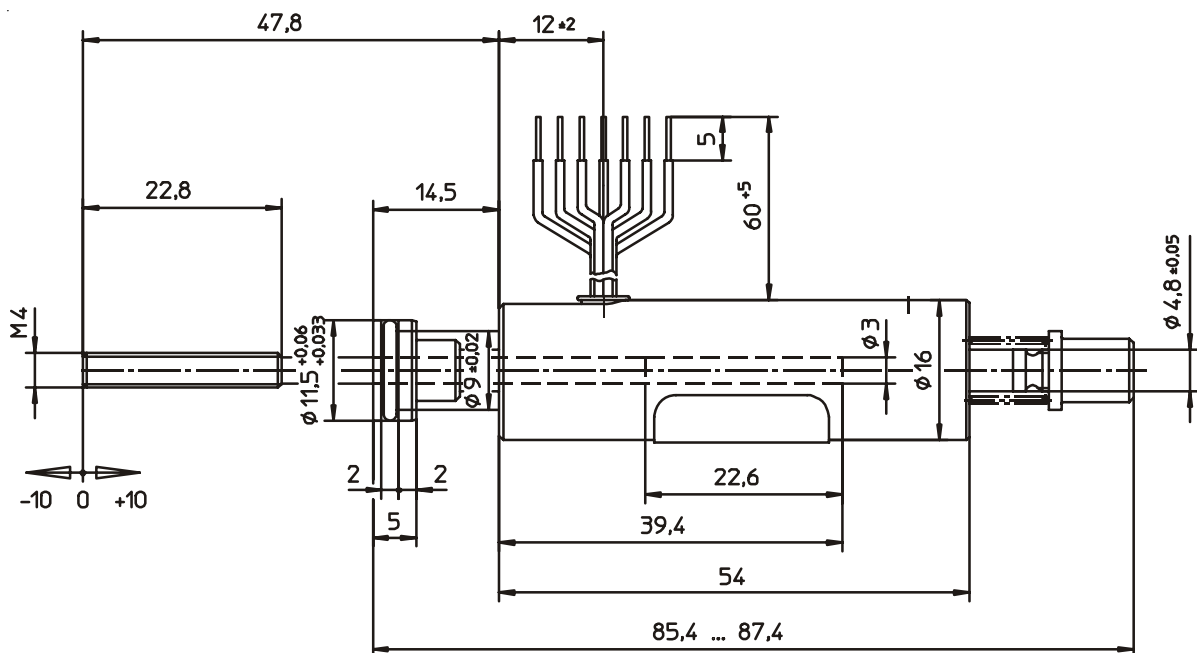

Fig. 5: Type A WX X 010 A01

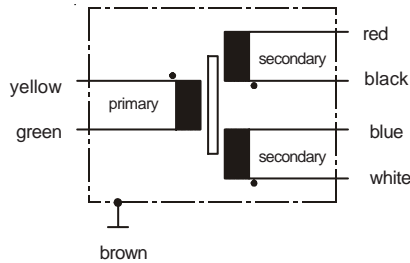

Fig. 6: Connection diagram A WX X 010 A01

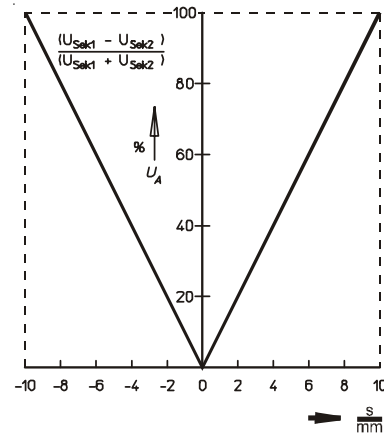

Fig. 7: Voltage vs travel diagram for transducer A WX X 010 A01

Sensitivity for A WX X 010 A01

Sensitivity is the change in the output signal with reference to the change in the measuring path

(indicated in $\left[\frac{\text{mV}}{\text{V} \cdot \text{mm}} \right]$).

$$\text{Sensitivity} = \frac{\Delta U_A}{\Delta s}$$

Linearity error

The linearity error indicates the deviation of the output signal from the ideal graph in per cent.

$$\text{Deviation}_{\text{Lin}} = \frac{(U_{\text{actual}} - U_{\text{nominal}})}{U_{\text{voltage stroke}}} \times 100 \%$$

Temperature drift

Temperature drift indicates in per cent the deviation of the output signal per degree of temperature change (shown in % / °k).

$$\text{Deviation}_{\text{Temp.}} = \frac{(U_{\text{Temp}} - U_{20^\circ\text{C}})}{U_{\text{voltage stroke}} \times \Delta T} \times 100 \%$$

Output Voltage

The output voltage

$$\text{Output voltage } U_A = \frac{(U_{\text{sec1}} - U_{\text{sec2}})}{(U_{\text{sec1}} + U_{\text{sec2}})}$$

Type code

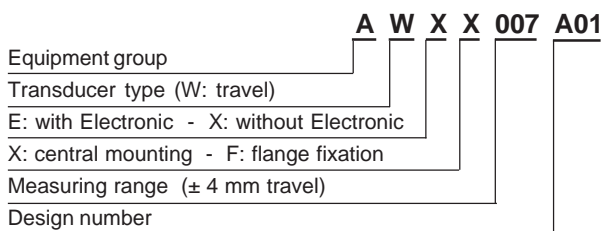

Order Example

Type A WX X 007 A01

Specials

Special designs and modifications are available on request for which full application conditions should be specified in accordance withour -Technical Explanations.